

| LOC | DIST | REVISIONS | | | | | |
|-----|------|-----------|-----|---|---------|-----|------|
| FI | 25 | P | LTR | DESCRIPTION | DATE | DWN | APVD |
| | | C | | REDWN & ADD: -5; NPR C96-153 & FC 0N20-0013-96 | 10JUL96 | GG | NJ |

1. WIDTH - 3/4 INCH
2. THICKNESS - .007 INCH
3. VOLTAGE RATING - 600 VRMS
4. TEMPERATURE RATING - 80°C
5. SHIPPING WEIGHT 84.2 GRAMS / 3 oz.
6. PVC FLAME RETARDED BLACK.

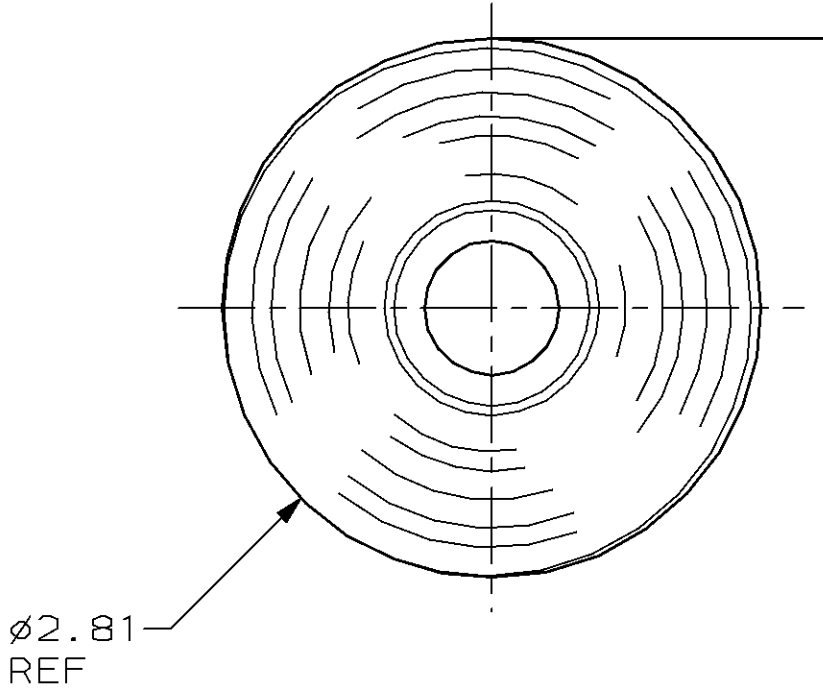

| | | |
|--------|--|----------|
| 20 FT. | BULK PACKED INDIVIDUAL ROLLS | 604271-5 |
| 66 FT. | 10 ROLLS PER SLEEVE INDIVIDUALLY WRAPPED | 604271-2 |
| LENGTH | DESCRIPTION | PART NO. |

RELEASED FOR PUBLICATION

THIS DRAWING IS UNPUBLISHED.

BY AMP INCORPORATED. ALL RIGHTS RESERVED.

| | |
|--|----|
| DIMENSIONS: INCHES | |
| TOLERANCES UNLESS OTHERWISE SPECIFIED: | |
| 0 PLC | ±- |
| 1 PLC | ±- |
| 2 PLC | ±- |
| 3 PLC | ±- |
| 4 PLC | ±- |
| ANGLES | ±- |

| | |
|-------------------|---------|
| DWN G. GARRETT | 10JUL96 |
| CHK N. JONES | 15JUL96 |
| APVD E. HRYN | 19JUL96 |
| PRODUCT SPEC | - |
| APPLICATION SPEC | - |
| WEIGHT | - |

| | | | |
|---|-----------|------------|--------|
| MATERIAL | | FINISH | - |
| AMP Incorporated Harrisburg, PA 17105-3608 | | NAME | |
| TAPE, PVC ELECTRICAL BLACK | | | |
| SIZE | CAGE CODE | DRAWING NO | |
| A4 | 00779 | C-604271 | |
| CUSTOMER DRAWING | | SCALE | 1:1 |
| | | SHEET | 1 OF 1 |
| | | REV | C |