

# **RL** RED LION CONTROLS

**INTERNATIONAL HEADQUARTERS**  
20 Willow Springs Circle, York, Pa. 17402, (717) 767-6511 FAX: (717) 764-0839  
Web site- <http://www.redlion-controls.com> E-mail- [sales@redlion-controls.com](mailto:sales@redlion-controls.com)

**EUROPEAN HEADQUARTERS**  
892 Plymouth Road, Slough, Berkshire SL1 4LP  
ENGLAND +44 1753 696888 FAX: +44 1753 696339

## MODEL IMS - APOLLO 4½ DIGIT INTELLIGENT STRAIN GAGE METER

- 40,000 COUNT MEASUREMENT RESOLUTION  
(can be scaled to ±99,999 display)
- ACCEPTS LOW LEVEL INPUTS FROM 20 mV to 200 mV FULL SCALE
- USER SELECTABLE BRIDGE EXCITATION (5 VDC or 10 VDC)
- EASY ONE-PASS SCALING
- STATE-OF-THE-ART DIGITAL ELECTRONICS FOR GREATER ACCURACY AND RELIABILITY
- FULL 6-DIGIT, HIGH VISIBILITY, 0.56" (14.2 mm) HIGH RED LED DISPLAY
- PROGRAMMABLE FRONT PANEL LOCK-OUT MENU
- INTEGRATOR (totalizer) AND LINEARIZER
- DIGITAL TARE (re-zero) AND PEAK/VALLEY (max/min) RECORDING
- DUAL ALARM RELAY OUTPUTS (optional)



- BI-DIRECTIONAL SERIAL COMMUNICATIONS (optional)
- 4 to 20 mA or 0 to 10 VDC ANALOG OUTPUT (optional)
- NEMA 4/IP65 SEALED METAL FRONT BEZEL

### DESCRIPTION

The Apollo Intelligent Strain Gage Meter (IMS) accepts low level signals from a variety of bridge-type transducers, such as load cells, pressure transducers, torque transducers, etc. User selectable low (20 mV) and high (200 mV) input ranges and a stable, bridge excitation voltage, that is user selectable 5 V or 10 V at 60 mA, is provided. A two Hz, two pole, low pass filter coupled with programmable digital filtering can be tuned to match the characteristics of most processes. A digital tare (re-zero) operation can be performed at a touch of a button along with recall of process peak and valley (max/min) values. State-of-the-art digital circuitry virtually eliminates errors due to drift. A full complement of option packages are available to fulfill many process applications.

The indicator features a choice of two different scaling procedures which greatly simplifies initial set-up. A full 6-digit display accommodates virtually any process-engineering unit. English Style display prompts aid the operator through set-up and operation. A front panel lock-out menu protects set-up data and operation modes from unauthorized personnel. Programmable remote input E1-CON and/or E2-CON, can be utilized to control a variety of totalizing, alarm control, display hold and tare operations. All set-up data is stored in E<sup>2</sup>PROM, which will hold data for a minimum of 10 years without power.

As a standard feature, all units include an integrator (totalizer)/ linearizer which can be used to totalize or integrate signals up to a maximum display value of 999,999. It features independent scaling and a low signal cut-out to suit a variety of signal integration applications. Additionally, nine slopes and offsets can easily be programmed to linearize transducers with non-linear outputs, such as square law devices. All readings are retained at power-down.

Optional dual relays with parallel solid state outputs are fully programmable to operate in a wide variety of modes to suit many control or alarm applications.

Optional 20 mA loop, bidirectional serial communications provides computer and printer interfacing to extend the capabilities of the indicator. More than one unit can be connected in the loop with other RLC products which have serial communications capabilities.

An optional 4 to 20 mA or 0 to 10 VDC re-transmitted analog output can be scaled by the user to interface with a host of recorders, indicators and

controllers. The indicator has several built-in diagnostic functions to alert operators of any malfunction. Extensive testing of noise interference mechanisms and full burn-in makes the indicator extremely reliable in industrial environments. The die-cast front bezel meets NEMA 4/IP65 requirements for washdown applications. Plug-in style terminal blocks simplify installation wiring and change-outs.

### SAFETY SUMMARY

All safety related regulations, local codes and instructions that appear in the manual or on equipment must be observed to ensure personal safety and to prevent damage to either the instrument or equipment connected to it. If equipment is used in a manner not specified by the manufacturer, the protection provided by the equipment may be impaired.

Do not use this unit to directly command motors, valves, or other actuators not equipped with safeguards. To do so, can be potentially harmful to persons or equipment in the event of a fault to the unit.

### SPECIFICATIONS

- DISPLAY:** 6-digit, 0.56" (14.2 mm) High LED, minus sign displayed for negative values. Flashing display during totalizer overflow. "....." displayed for input out of range. "OLOLOL" displayed for input overload and "ULULUL" displayed for underload (negative overload).
- POWER REQUIREMENTS:**  
**A.C. Power:** Switch Selectable 115/230 VAC, ±10%, 50/60 Hz, 14 VA.
- CONTROLS:** Three front panel push buttons for modifying alarm values and indicator set-up. Two external inputs for disabling the front panel and controlling programmable functions.
- SIGNAL INPUT RANGE:** Max. common mode voltage swing with respect to signal ground, 0 to 7 V.  
*Note: Absolute max. voltage that can be applied between the two input terminals or between input and signal common is 75 VDC.*  
**Jumper selectable:** ±20 mV or ±200 mV.
- DEADLOAD RANGE:** -100%, +5% of range selected.

### DIMENSIONS "In inches (mm)"

Note: Recommended minimum clearance (behind the panel) for mounting clip installation is 2.1" (53.3) H x 5.5" (140) W.

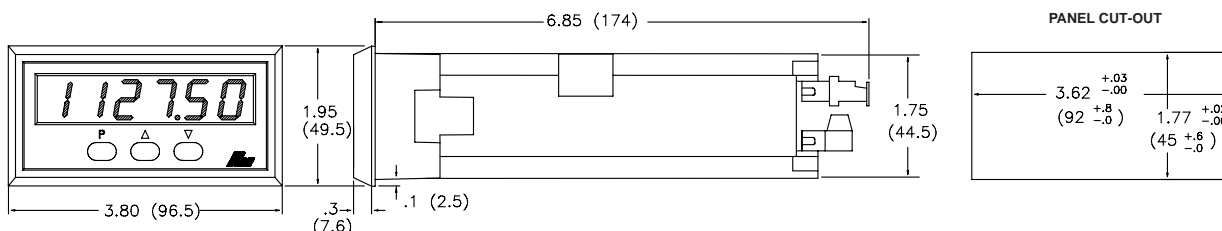

## SPECIFICATIONS (Cont'd)

### 6. BRIDGE EXCITATION:

**Jumper selectable:** 5 VDC or 10 VDC @ 60 mA max., overload protected.

**Drift:** <50 ppm/°C, non-ratiometric.

### 7. LINEARITY, ACCURACY AND RESOLUTION:

**Linearity:** 0.03% FS

**Accuracy:** 20 mV range; 0.03% FS.

200 mV range; 0.5% FS Nominal, may be calibrated to 0.03% FS.

**Resolution:** 1/40,000 counts.

**Relative Humidity:** Less than 85% RH

### 8. PROGRAMMABLE DISPLAY READING RANGE: -99999 to 999999

### 9. SIGNAL CONNECTION: 4-Wire

### 10. INPUT RESISTANCE: 100 MΩ

### 11. READING RATE: 2.5 readings/second

### 12. RESPONSE TIME: 2 seconds to settle for step input (increases with programmable digital filtering)

### 13. TOTALIZER: Front Panel button for input/total display select. Programmable time-base, scale factor (0.001 to 100.000) and low-end cut-out. Response Time = 0.2 secs. max.

### 14. E1-CON AND E2-CON: External remote inputs which allow activation of various functions. (Reset total, peak indicator mode, trigger mode, etc).

$V_{IL} = 0.8 V_{MAX}$ ;  $V_{IH} = 2.0 V_{MIN}$ ; Response Time = 0.2 sec. max.

### 15. NORMAL MODE REJECTION: 80 dB at 50/60 Hz (may be improved by programmable digital filtering)

### 16. COMMON MODE REJECTION: 120 dB, DC to 50/60 Hz, with respect to earth common.

60 dB, DC to 50/60 Hz, w/respect to excitation common.

### 17. ENVIRONMENTAL CONDITIONS:

**Operating Temperature Range:** 0 to 50°C

**Storage Temperature Range:** -40 to 80°C

**Span Temperature Coeff.:** 70ppm/°C

**Zero Temperature Coeff.:** 1μV/°C

**Operating and Storage Humidity:** 85% (non-condensing) from 0 to 50°C

**Altitude:** Up to 2000 meters.

### 18. SERIAL COMMUNICATIONS (Optional):

**Type:** Bi-directional 20 mA current loop, 20 mA source provided on transmit loop. (Powers up to 7 units in a loop with internal current source.)

**Baud Rate:** Programmable 300 to 2400

**Maximum address:** 99 (Actual number in a single loop is limited by serial hardware specifications.)

**Data Format:** 10 bit frame, Odd parity (one start bit, 7 data bit, one odd parity bit, and one stop bit.)

#### Serial Hardware Specifications:

**SO - Output Transistor Rating:**  $V_{MAX} = 30$  VDC,

$V_{SAT} = 1 V_{MAX}$  at 20 mA.

Note: This will allow up to 28 units max. in each loop.

**SI - Input Diode Rating:**  $V_F = 1.25 V_{TYP}$ ;  $1.5 V_{MAX}$

Note: The compliance voltage rating of the source must be greater than the sum of the voltage drops around the loop. (Typically a 30 VDC powered source would be capable of operating between 18 and 22 units in a loop.)

### 19. ALARMS (Optional):

**Solid State:** Two, isolated sinking open collector NPN transistors acting in parallel with relays.

$V_{SAT} = 1V$  @ 100 mA max.  $V_{MAX}$ : 30 VDC.

#### Relays:

**Type:** Form C (2)

**Max. Rating:** 5 Amps @ 120/240 VAC or 28 VDC (resistive load), 1/8 HP @ 120 VAC (inductive load).

**Relay Life Expectancy:** 100,000 cycles at Max. Rating. (As load level decreases, life expectancy increases.)

### 20. ANALOG OUTPUT: Digital scaling and offsetting.

#### 4 to 20 mA:

**Accuracy:** 0.1 of full scale

**Resolution:** 12 bits

**Compliance Voltage:** 10 VDC (500 W max. loop impedance)

#### 0 to 10 VDC:

**Accuracy:** ± (0.1% of reading +35 mV)

**Resolution:** 12 bits

**Min. Load Resistance:** 10 KW (1 mA max.)

### 21. LINEARIZER/PEAK/VALLEY/TARE:

9-segment multiple slope scaling for non-linear inputs. Peak and valley recording, signal and rezero (tare).

### 22. CERTIFICATIONS AND COMPLIANCES:

#### EMC EMISSIONS:

Meets EN 50081-2: Industrial Environment.

CISPR 11 Radiated and conducted emissions

#### EMC IMMUNITY:

Meets EN 50082-2: Industrial Environment.

ENV 50140 - Radio-frequency radiated electromagnetic field <sup>1</sup>

ENV 50141 - Radio-frequency conducted electromagnetic field <sup>1</sup>

EN 61000-4-2 - Electrostatic discharge (ESD)<sup>2</sup>

EN 61000-4-4 - Electrical fast transient/burst (EFT)<sup>2</sup>

EN 61000-4-8 - Power frequency magnetic field

#### Notes:

1. Unit complies with listed specifications at 10 V/m and 10 Vrms when installed as follows:

a. Install power line filter, RLC #LFIL0000 or equivalent.

b. Install unit in a Buckeye SM 7013-0 enclosure or equivalent.

c. Install all I/O cables connecting to the unit in metal conduit that is connected to the enclosure at one end, and earth ground at the opposite end.

2. Metal bezel of unit connected with ground lead from rear bezel screw to metal mounting panel.

Refer to the EMC Installation Guidelines section of the manual for additional information.

23. **CONSTRUCTION:** Die-cast metal front bezel that meets NEMA 4/IP65 requirements for indoor use when properly installed. Installation Category II, Pollution Degree 2. Case body is black, high impact plastic (panel gasket and mounting clips included).

24. **CONNECTION:** Removable terminal blocks.

25. **WEIGHT:** 1.2 lbs (0.54 kg).

## TOTALIZER/LINEARIZER/PEAK/VALLEY/TARE

The integrator feature simply totals (adds) input readings with a programmable time base and scaling coefficient. The integrator/totalizer may be reset via a remote input, by the front panel or through the serial communications loop. Alarms may be programmed to trigger from totalizer values, for example to signal total weight thresholds for batching operations. A programmable low signal level disable feature completes the integrator/totalizer features. At loss of power to the indicator, the contents of the totalizer are saved.

The linearizer feature is a series of programmable scaling points that are used to construct linear segments to linearize the input signal. The most common application would be to interface with square law devices. A maximum of nine segments are available and using nine segments for a square law device would reduce linearity errors to less than 0.5%.

The other features are peak and valley detection and a re-zero (tare) function. The indicator will record the lowest reading (valley) and the highest reading (peak) automatically, for later recall. This information is valuable when monitoring the limits of the process over any length of time (shifts, days, etc.) since these values are stored at power-down. An external input can be programmed to reset or engage the unit into a peak or valley reading indicator. Additionally, the peak and valley can be viewed and reset from the front panel, if so programmed, and viewed and reset through the serial communication option.

The re-zero (tare) function can also be controlled externally or by the front panel. This feature can quickly compensate for small shifts or drifts in the input signal or can be used to re-zero after every operation, such as batching.

## ISOLATED ALARM OPTION

The alarm option consists of an additional printed circuit board with 9 connections. Six of these terminals are for the two Form-C relays and the other three are for the two open collector transistors, which act in parallel with the relays. The two alarms are completely independent with programmable values, hysteresis (deadband), high or low acting, auto or manual reset, triggering from input or total, and they can be programmed to track each other, if desirable. If the alarms are programmed to latch (manual reset), then they can be reset either by the front panel or a remote input. The alarms can be set to trigger from either the integrator/totalizer or the input display, such as actuating external alarms, control valves, etc.

Alarm #1 can be programmed to track Alarm #2 by enabling alarm tracking. This is useful in alarm set-ups where a pre-warning control activates before a second alarm shuts off the process when tracking is programmed. Changing the shut-off trip value (alarm #2) automatically changes the pre-warn value (alarm #1) an equal amount. Alarm and hysteresis values can be modified through the optional serial communications to provide automatic control.

## ISOLATED SERIAL COMMUNICATIONS OPTION

The serial communication option is a half-duplex, two-way 20 mA loop that can connect to a variety of printers, computers, terminals and controllers to suit many data-polling or automatic operation applications. The indicator responds to a host of commands, including change alarm value, reset totalizer and transmit input signal. Two loops are required for all hook-ups; a transmit (outgoing data) loop and a receive (in-coming data) loop. Since the indicator monitors the receive loop for a busy signal (current interrupted) while transmitting, the receive loop must be connected even if the indicator is transmitting only, such as to a printer. A built-in 20 mA source is provided in the transmit loop. Additionally, multiple units and other Red Lion Controls instruments can be serially addressed, with a maximum address capability of 99 units. (Note: There are hardware limitations which restrict this to a lower number of units per serial loop.)

## ISOLATED RE-TRANSMITTED ANALOG OUTPUT OPTION

### 4 to 20 mA

The re-transmitted analog output option transmits a digitally programmable 4 to 20 mA current to drive chart recorders, remote indicators and controllers. The compliance is 10 VDC. Non-standard current ranges within the 4 to 20 mA range can be supported by calculating the slope and intercept of the display/output and calculating the required display values at 4 and 20 mA.

### 0 to 10 VDC

The re-transmitted analog output option transmits a digitally programmable 0 to 10 VDC output signal to drive chart recorders, remote indicators and controllers. Non-standard current ranges within the 0 to 10 VDC range can be supported by calculating the slope and intercept of the display/output and calculating the required display values to 0 VDC and 10 VDC.

### PROGRAMMABLE FUNCTIONS

Programming of the IMS is divided into modular steps. Each module is a short sequence of data entries. The front panel buttons "UP" and "DOWN" (shown as arrows on the front panel) are used to change the data and set-ups, while the "P" button is used to 'save' or 'enter' the data. After pressing "P" which gains entry into the programming mode, the programming modules are identified by the message "Pro" and a number in the display. "UP" and "DOWN" are used to select the desired programming module and "P" is used to enter it. All of the subsequent programming steps follow the same procedure. The rear terminal labeled "PGM. DIS." must be disconnected from ground to gain access to programming. The following table lists the programming steps.

#### "Pro 0" - RETURN TO MEASUREMENT MODE

#### "Pro 1" - SCALE UNIT BY APPLYING SIGNAL

- "dECPNt" - Enter decimal point for scaled display
- "round" - Enter rounding factor and trailing zeros for scaled display
- "SCALE" - \*
- "dSP 1" - Enter display reading for scaling point #1
- "INP 1" - Apply signal level for scaling point #1
- "dSP 2" - Enter display reading for scaling point #2
- "INP 2" - Apply signal level for scaling point #2
- "SEGT" - \*

#### "Pro 2" - SCALE UNIT BY KEY-IN SIGNAL LEVEL

- "dECPNt" - Enter decimal point for scaled display
- "round" - Enter rounding factor and trailing zeros for scaled display
- "SCALE" - \*
- "dSP 1" - Enter display reading for scaling point #1
- "INP 1" - Enter signal level for scaling point #1
- "dSP 2" - Enter display reading for scaling point #2
- "INP 2" - Enter signal level for scaling point #2
- "SEGT" - \*

#### "Pro 3" - PROGRAM FUNCTIONS ACCESSIBLE WITH FRONT PANEL LOCKOUT ENGAGED

- "dSP AL" - Enable display alarms
- "ENt AL" - Enable enter alarms †
- "dSPHYS" - Enable display hysteresis
- "ENtHYS" - Enable enter hysteresis †
- "rSt AL" - Enable reset latched alarms
- "dSPbUF" - Enable display of peak/valley readings
- "rStbUF" - Enable reset of peak/valley readings †
- "SELdSP" - Enable switching display between input and total
- "rSttOt" - Enable reset total
- "tArE" - Enable re-zero (tare) of input signal

#### "Pro 4" - PROGRAM DIGITAL FILTERING AND REMOTE INPUT FUNCTION

- "FILter" - Enter level of digital filtering
  - 0 - no digital filtering
  - 1 - normal level
  - 2 - increased level
  - 3 - maximum level

\* - Entire sequence for this modular step is not shown (see manual for further details).

† - This sequence may be subject to being locked-out due to other programmed sequences.

- "E1-CON" - Enter function of remote input
  - 0 - re-zero input
  - 1 - reset total
  - 2 - reset and gate totalizer
  - 3 - gate totalizer
  - 4 - display hold
  - 5 - reset peak/valley
  - 6 - reset peak and start peak indicator
  - 7 - reset valley and start valley indicator
  - 8 - reset latched alarms
  - 9 - reset all alarms
  - 10 - switch display (total/input)
  - 11 - rezero input and totalize the tared values
  - 12 - Display hold with tare
  - 13 - Instrument reading synchronization
  - 14 - Print request

"E2-CON" - Same functions as E1-CON

#### "Pro 5" - PROGRAM TOTALIZER

- "dECPNt" - Enter decimal point position for totalizer
- "tbASE" - Enter time base
  - 0 - second
  - 1 - minute
  - 2 - hour
- "SCLFAC" - Enter multiplying scale factor
- "Lo-cut" - Enter low-signal cut out

#### "Pro 6" - PROGRAM ALARMS

- "trAc" - Enable alarm value tracking
- "dISP" - Enable display alarm annunciators
- "LAtC-1" - Enable alarm #1 latching
- "ASN-1" - Enter alarm #1 trigger source (input or total)
- "AL-1" - Enter alarm #1 value
- "HYS-1" - Enter hysteresis value for alarm #1
- "Act-1" - Enter alarm #1 action (high or low)
- "LAtC-2" - Enable alarm #2 latching
- "ASN-2" - Enter alarm #2 trigger source (input or total)
- "AL-2" - Enter alarm #2 value
- "HYS-2" - Enter hysteresis value for alarm #2
- "Act-2" - Enter alarm #2 action (high or low)

#### "Pro 7" - PROGRAM SERIAL COMMUNICATIONS

- "bAud" - Enter baud rate
- "AddrES" - Enter loop address number (0-99)
- "Print" - Enter print switch function, or "P" command function through Serial Option
  - 0 - input
  - 1 - input, peak/valley and tare
  - 2 - input and alarms
  - 3 - input, peak/valley, alarm, hysteresis, and tare
  - 4 - total
  - 5 - input, total
  - 6 - input, total, peak/valley, and tare
  - 7 - total and alarms
  - 8 - input, total and alarms
  - 9 - input, total, peak/valley, alarms, hysteresis, and tare
- "FULL" - Enable abbreviated printing

#### "Pro 8" - PROGRAM RE-TRANSMITTED ANALOG OUTPUT

- "ASIN" - Select source of analog output (input or total)
- "AN-Lo" - Enter 4 mA or 0 VDC display value
- "AN-HI" - Enter 20 mA or 10 VDC display value

#### "Pro 9" - SERVICE OPERATIONS (Protected by access codes)

## IMS FORMULA BATCHING APPLICATION

An IMS is used to display the weight of the contents of a hopper used to formulate dry soap mixes. A hopper weighing 1100 lb. is required to produce batches of 600 lb. A total of 1700 lb. must be supported. Therefore, two 1000 lb., 350  $\Omega$  compression load cells are used. The sensitivities of the load cells are 2 mV/V and the excitation voltage is 10 volts, producing a signal output of 11 mV when the hopper is empty and 17 mV when full. The 20 mV input range is selected, and display resolution is 0.5 lbs.

The load cells are connected to the IMS. Scaling procedure "PRO 1" is used by emptying the hopper and keying in a display value of "0.0" lbs. Then 600 lbs. of material is emptied into the hopper and "600.0" lbs. is entered. Scaling is completed, including compensation for the weight of the hopper.

Batching is accomplished by wiring a switch to the remote input E1-CON of the indicator. As each ingredient is mixed in, its weight is displayed. The display can be re-zeroed by the switch, allowing the next ingredient to be mixed into the batch. When the formula is complete, the mixing hopper is emptied and re-zeroed, ready for the next batch.

### BASIC PROGRAMMING STEPS (Unit set-up)

- "PRO 1"....." dECPNt" - 0.0
- "round" - 0.5
- "SCALE" - YES
- "dSP 1" - 0.0 (lbs.)
- "INP 1" - Empty hopper, input 11 mV DC from transducer
- "dSP 2" - 600.0 (lbs.)
- "INP 2" - Fill hopper, input 17 mV DC from transducer
- "SEGT" - 1

THIS COMPLETES BASIC SET-UP PROGRAMMING FOR THE ABOVE EXAMPLE.

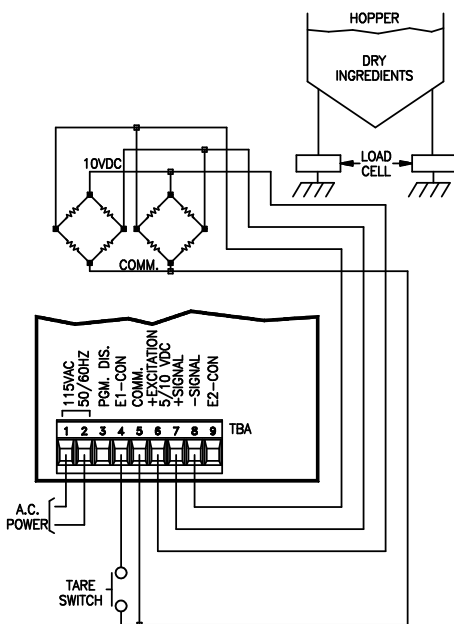

## STEAM PRESSURE MONITOR/DISPLAY APPLICATION

An IMS is used to monitor and display the steam pressure within an oil-fired generating station. A pressure transducer with a 3 mV/V output over a 0 to 2500 psi range is used. The 5 volt excitation supply is selected, resulting in a 15 mV full scale output. The 20 mV input range of the IMS is used. After connecting the transducer, scaling is accomplished by entering into the "PRO-1" mode and entering in "0" psi when the line pressure is 0, and entering in the exact line pressure, when pressure is taken at full scale ( $\approx$  2500 psi).

During operation, the tare function can be used to re-zero the display to compensate for small shifts in the transducer. The optional dual alarms are used as high/low pressure limit detectors. The indicator's max/min signal recording is used as an aid for unattended operation. The 4 to 20 mA re-transmitted analog output drives a second, remotely located display and is also looped with a hard-copy chart recorder for process analysis.

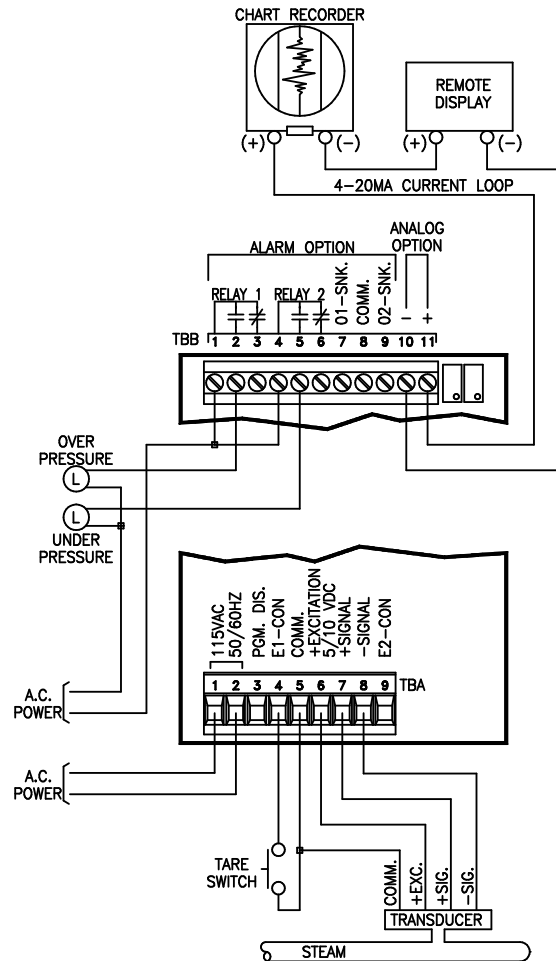

### ORDERING INFORMATION

MODEL NO.	DESCRIPTION	OPTIONS			PART NUMBERS FOR AVAILABLE SUPPLY VOLTAGES
		DUAL ALARM	SERIAL COMMUNICATIONS	ANALOG OUTPUT	
IMS	Intelligent Strain Gage Meter	NO	NO	NO	115/230 VAC
		YES	NO	NO	IMS03160
		YES	YES	NO	IMS03162
		YES	NO	4 to 20 mA	IMS03164
		YES	YES	0 to 10 VDC	IMS03166
					IMS03168

For more information on Pricing, Enclosures & Panel Mount Kits refer to the RLC Catalog or contact your local RLC distributor.